



Presentation
Systems Inc.

Phone: 1-800-244-6381

Fax: 1-973-304-1870

Website: www.presentationssystem.com

103 Godwin Ave PMB 204, Midland Park, NJ 07432

ecool 25" Cold Laminator

Features & Functions:

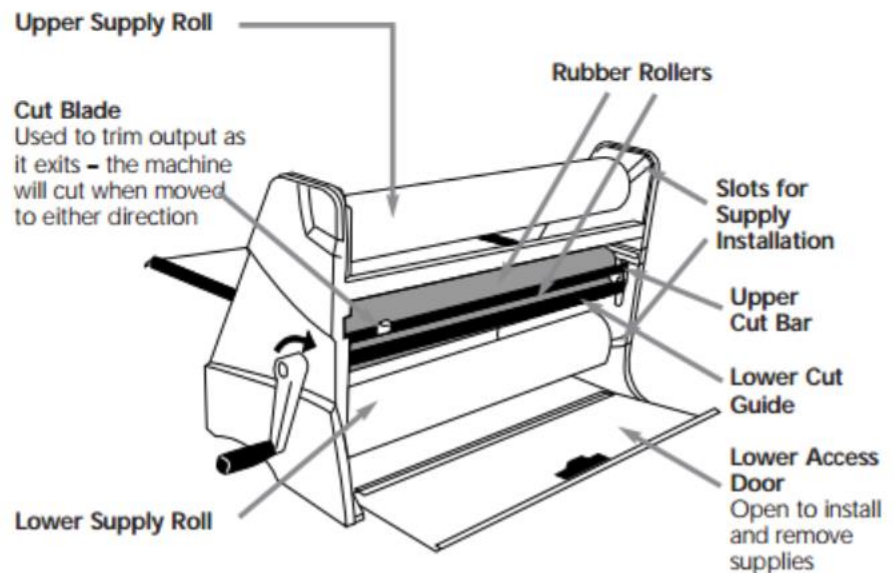
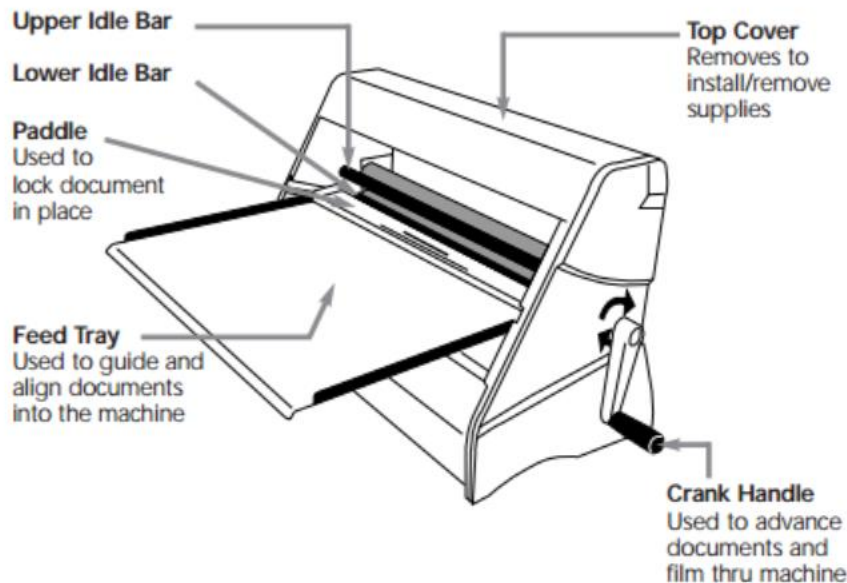

Setting Up:

Remove the machine from the packaging and place on a level surface. Locate the crank handle which is taped to the bottom inside of the machine.

Install the crank handle by carefully threading clockwise (direction of the arrows) into the lower rubber roller.

Cut the tie wraps holding the upper cut bar and lower guide together.

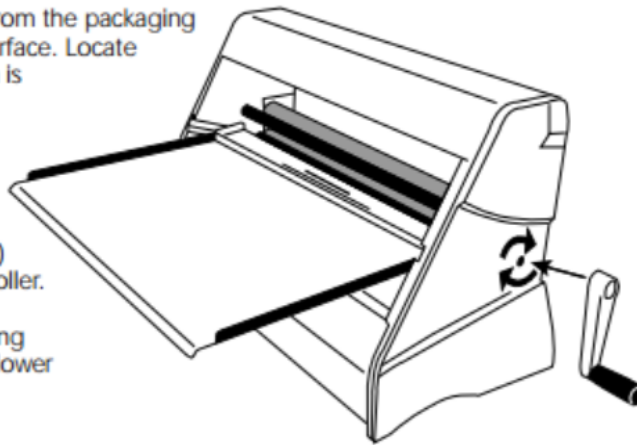

Loading Supply Rolls:

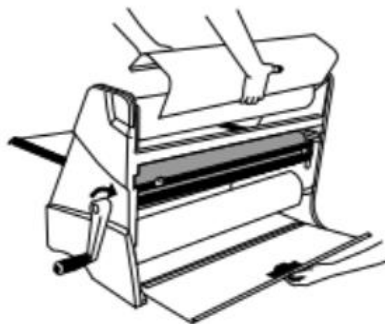

Step 1:

- Remove the top cover of the machine by lifting upward.
- Grasp the handle on the lower access door; pull to open.



Step 2:

- Match the colored dots on the end of each supply roll with the corresponding dots on the side of the machine. Note which roll is identified as "top" and "bottom".
- Slide the supply rolls into the grooves in the sides of the machine, making certain that the roll is inserted completely.

Loading Supply Rolls (cont):



Step 3:

- On the bottom supply roll, grasp the laminated starter section by the leading edge film.
- Route over the bottom idler bar adjacent to the lower rubber roller.
- Make sure the film is inserted squarely. Rotate the handle 1/4 turn in the direction of the arrows.



Step 4:

- Make certain the lower film is tight. If necessary, rotate the supply roll in the direction of the arrows until the film is taut.
- Grasp the film from the upper supply roll and adhere it to the film on the lower supply roll.

By carefully aligning the edges, keeping the film tight and avoiding wrinkles, film waste will be minimized.



Step 5:

- Rotate the handle to pull the supplies through the machine.
- Ensure that the film exits between the blade bars.
- Just before the top film becomes tight again, insert a small piece of cardstock between the rubber rollers. This will help to minimize waste and ensure the film exits between the upper cut bar and lower guide.

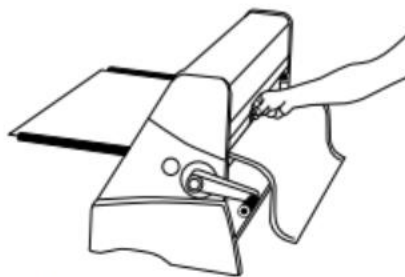

Step 6:

- Continue to crank film through machine until it is aligned and wrinkle-free.
- Trim off excess film by pressing down on the blade holder and sliding in either direction.



Step 7:

- Replace the top cover.
- Close the lower access door.
- Install feed tray completely by aligning the support posts in the grooves located in the sides of the machine.

When done correctly, the film layers should be aligned and wrinkle-free after 18" (45cm) of material has exited the machine.

Basic Operation:

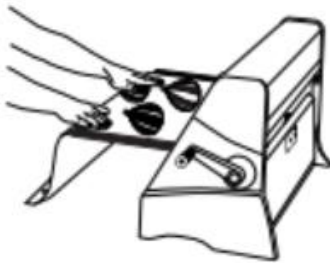

Step 1:

- Pull back on the paddle so that it is in the "up" position.
- Insert a document so the leading edge is under the paddle. The document should extend past the edge of the paddle 1-2 inches (2.5-5cm).

Note: The side of the document which is face down will have adhesive applied when using 1 Side Laminate/1 Side Mounting Adhesive.

- Align the document parallel to the edge of the feeder tray.



Step 2:

- Push forward on the paddle to lock the document in place.
- Ensure that the leading edge of the document is adhered down evenly. If necessary slide your fingers across the leading edge to secure it in place.
- Turn the handle clockwise to advance the document through the machine.



Step 3:

- Trim the document by pressing down on the blade holder and sliding it in either direction.

Note: As the document exits the machine, you may wish to trim the leading edge. This will avoid a later trimming operation.